

## RP99Si

H



RP99Si is a heavy duty automatic door bottom seal which is spring loaded to lift clear off the floor as soon as the door [leaf](#) is opened by a few millimetres.

RP99Si has an extruded silicon component for medium temperature smoke and is an acoustically designed seal for face mounted, [semi-morticed](#) or fully morticed applications. The door bottom seal is operated automatically by pressure against the door [jamb](#) on its adjustment block (strike).

**Note:** Face mount aluminium angle and all [escutcheon](#) plates included.

**Location** Solid core single and double [butt hinged](#) doors. Minimum door thickness 40mm recommended.

**Min/Max Gap** 1mm to 19mm.

**Seal Sizes** 1220mm, 1070mm, 920mm, 820mm, 720mm, 600mm, 380mm to 295mm (min). Seals cut back to exact size.

**Standard Finish** Aluminium anodised 15 microns. Satin Clear (Silver) or Bronze finish. [P.E. Paint](#) (at extra cost).

**Seal Material** [Silicon Rubber](#) (SE) (Black).

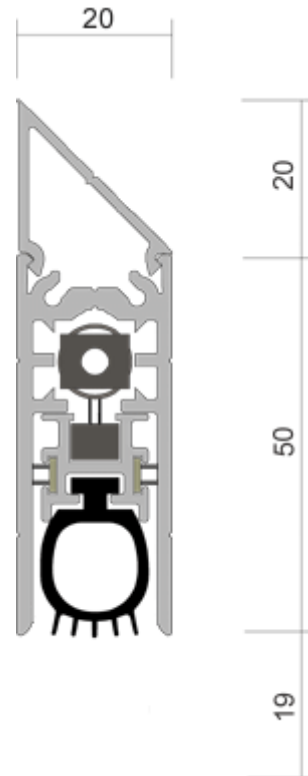

## Replacement Seal [RP347Si](#).

### Approvals

**Acoustic** AUS/NZ: Conforms to NCC BCA Spec. F5.5. Approved to AS 1191, AS 1045 & AS/NZS 1276.

UK/EU: Conforms to Approved Document E. Approved to BS EN ISO 140.3 (similar to BS EN ISO 717.1, BS 2750 & BS 5821).

**Fire & Smoke** AUS/NZ: Conforms to NCC BCA Spec. C3.4 for fire & smoke doors. Approved to AS 1530.4 & AS/NZS 1905.1. Meets requirements of NZ BC Compliance Doc. C/AS1 6.19.2 & App. C6.1.1.

UK/EU: Conforms to Approved Document B. Approved to BS 476 Pt. 20 & 22 (similar to BS EN 1634-1).

Approved on fire rated doors up to **FRL & FRR-/240/60 and FD240**🔥

Gasket flammability index 1 when tested to AS 1530.2.

**Smoke** Tested to AS 1530.7, ISO 5925-1 & EN 1634-3 (similar to BS 476 section 31.1). Meets smoke leakage rates specified in AS 6905 & EN 13501-2 "Sa", "Sm".

**Durability** tested to over 1,000,000 operating cycles without failure.

**Energy** Complies with NCC BCA Pt. 3.12.3.3 & J3.4 for Building Sealing and Energy efficiency.

### Patented.

